

CONFERENCES SEMINARS CELEBRATIONS

**We are delighted that you have shown an
interest in the CITY HOTEL Reutlingen**

Running your event
means a high degree of responsibility for us.

We would like to take the pressure off you - put your trust in our
proven way of organising things and allow us to run your event
so that you, as the host,
can focus on the most important things.

In the present conference documents
I have compiled information on the most important things for you.
I am available to speak to you personally at any time
if you require further information
or for detailed consultations.



CITY HOTEL Reutlingen

Events Manager
Paul Jurik

Am Echazufer 22
D-72764 Reutlingen, Germany

Tel.: 07121-924 630

Fax: 07121-924 444

E-mail address: bankett@city-hotel-reutlingen.de

CONTENTS

1. Packages

1.1 BASIC	package
1.2 CITY	package
1.3 Business	package

2. Rooms

2.1 Floor plan
2.2 Dimensions
2.3 Capacities
2.4 Checklist

3. Provision costs

3.1 Conference rooms
3.2 Conference technology
3.3 Food and drink

4. A description of the hotel

4.1 Facilities
4.2 Map with directions to the hotel

5. Supporting programmes & leisure time offers

1. Packages

1.1. "BASIC" package

1.2. "CITY" package

1.3. "Business" package



1.1. BASIC PACKAGE

€52.00 per person

Included:

Coffee break In the morning:	Selection of coffees and large selection of teas, ham and cheese croissants
Lunch:	2-course menu Main course and dessert A choice of 2 main dishes
Coffee break In the afternoon:	Selection of coffees and large selection of teas, madeira cake
Conference room:	A multi-functional conference room with daylight (seating in accordance with prior individual arrangements)
Standard technology:	1 overhead projector with screen 1 flip chart with paper and pens 3 pin boards Writing pad and pen for each participant
For additional requirements:	Group rooms are charged at €80.00 each Depending on requirements, technology is charged for in accordance with the system

€28.00 per person

Dinner:	2-course menu/buffet Choice of hot, vegetarian or cold main course
----------------	--

1.2. CITY PACKAGE

€56.00 per person

Included:

<i>Coffee break In the morning:</i>	Selection of coffees and large selection of teas, savoury oven-fresh snacks, muesli bar
<i>Lunch:</i>	Lunch buffet
<i>Coffee break In the afternoon:</i>	Selection of coffees and large selection of teas, fresh, colourful selection of fruit, sweet Danish pastries
<i>Conference room:</i>	A multi-functional conference room with daylight (seating in accordance with prior individual arrangements)
<i>Standard technology:</i>	1 overhead projector with screen 1 flip chart with paper and pens 3 pin boards Writing pad and pen for each participant
<i>For additional requirements:</i>	Group rooms are charged at €80.00 each Depending on requirements, technology is charged for in accordance with the system

€28.00 per person

<i>Dinner:</i>	2-course menu/buffet Choice of hot, vegetarian or cold main course
-----------------------	---

1.3. BUSINESS PACKAGE

€61.00 per person

Included:

<i>Coffee break In the morning:</i>	Selection of coffees and large selection of teas, savoury oven-fresh snacks, muesli bar
<i>Lunch:</i>	Lunch buffet
<i>Coffee break In the afternoon:</i>	Selection of coffees and large selection of teas, sweet Danish pastries fresh, colourful selection of fruit
<i>Drinks:</i>	Mineral water and apple juice in the seminar room 1 drink at lunch (selection of 0.3 litre drinks)
<i>Conference room:</i>	A multi-functional conference room with daylight (seating in accordance with prior individual arrangements)
<i>Standard technology:</i>	Overhead projector with screen 1 flip chart with paper and pens Pin board Writing pad and pen for each participant
<i>For additional requirements:</i>	Group rooms are charged at €80.00 each Additional services are charged for in accordance with the information provided in the seminar documents

€30.00 per person

<i>Dinner:</i>	2-course menu/buffet Choice of hot, vegetarian or cold main course
-----------------------	---

2. Rooms

2.1 Ground plan

2.2 Dimensions

2.3 Capacities

2.4 Personal checklist

2.1 Ground plan

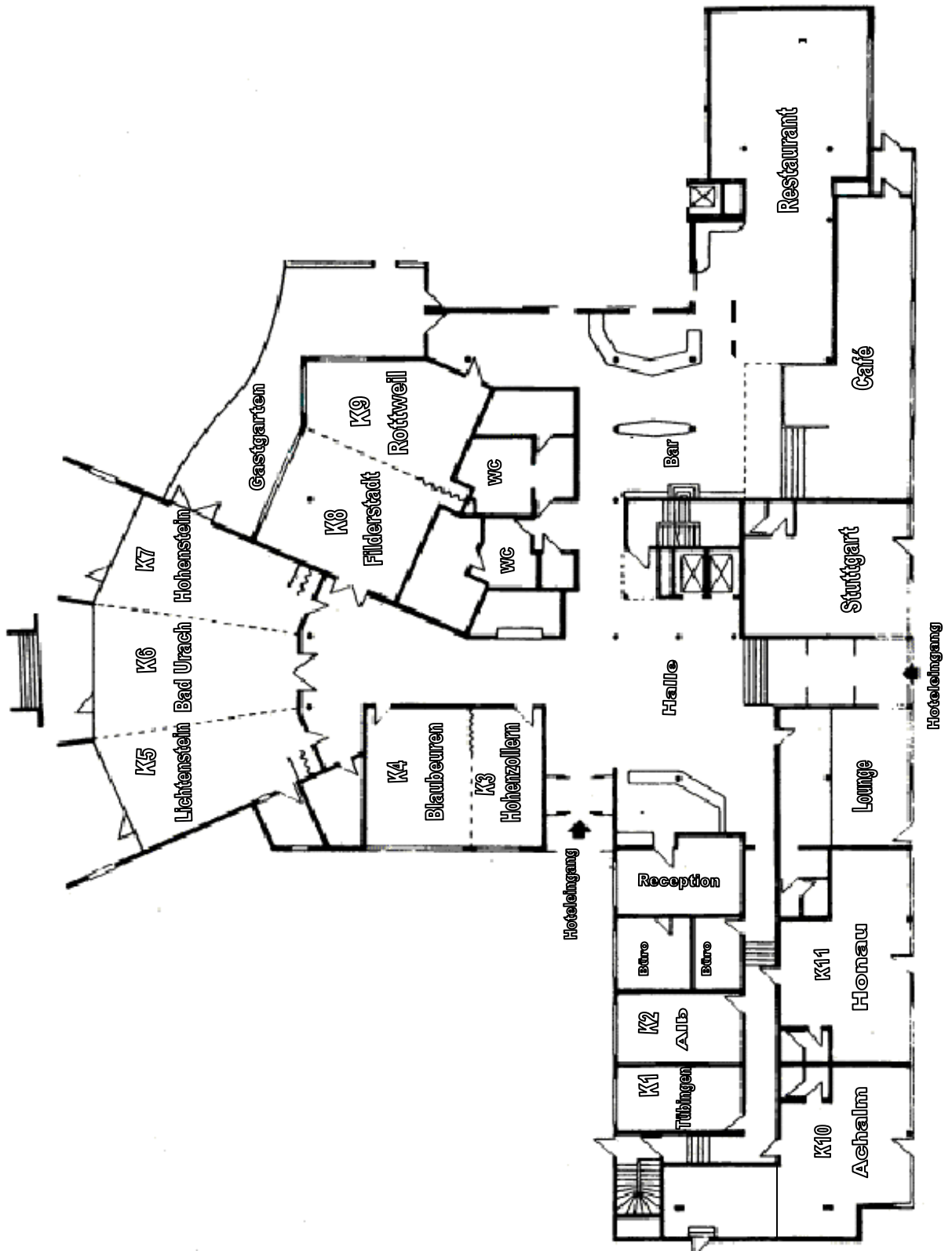



CONFERENCE ROOMS

2.2 Dimensions

Room	Length x breadth x height in metres	Surface area	Rooms combined
K1 Tübingen	7.40 x 3.50 x 3.20	26m²	
K2 Alb	7.40 x 3.50 x 3.20	26m²	
K3 Hohenzollern	7.60 x 3.80 x 3.00	29m²	K 3/4
K4 Blaubeuren	7.60 x 5.80 x 3.00	44m²	K 4
K5 Lichtenstein	10.00 x 6.50 x 3.50	65m²	K 5/6
K6 Bad Urach	10.00 x 8.00 x 3.50	80m²	K 5/6/7
K7 Hohenstein	10.00 x 6.50 x 3.50	65m²	K 6/7
K8 Filderstadt	8.00 x 7.50 x 3.00	60m²	K 8/9
K9 Rottweil	8.00 x 6.00 x 3.00	48m²	K 9
K10 Achalm		50m²	
K11 Honau		60m²	

2.3 Capacities of the rooms

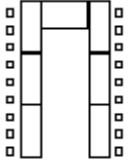
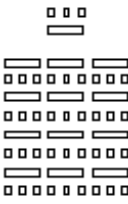
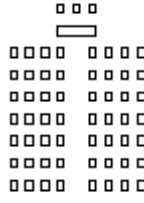
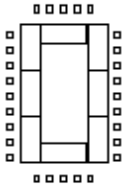
depending on the seating arrangements in each room

ROOM	S I Z E - - m ²	U-shaped outer (inner) 	Parliament 	Rows of seats 	Block- shaped 	Banquet Tables seating eight people (round) 
------	--	---	---	--	---	---

K1 Tübingen	26	---	---	---	16	---
K2 Alb	26	---	---	---	16	---
K3 Hohenzollern	29	15	20	30	15	---
K4 Blaubeuren	44	20 (30)	40	55	20	24
K3 + K4 Hohenzollern + Blaubeuren	73	30 (40)	60	80	35	48
K5 Lichtenstein	65	25	30	60	40	40
K6 Bad Urach	80	30 (50)	50	80	40	60
K7 Hohenstein	65	25	30	60	40	40
K5-K7 Licht./Bad Urach/Hohenstein	210	60 (100)	160	280	60	160/140
K8 Filderstadt	60	20	30	45	20	40
K9 Rottweil	48	16	20	25	25	24
K8 + K9 Filderstadt+Rottweil	108	40 (50)	70	110	45	80/56
K10 Achalm	50	15	---	---	15	---
K11 Honau	60	25	40	50	25	---

PERSONAL CHECKLIST

for your successful in the CITY HOTEL Reutlingen

Company: _____

Contact person: _____

Street: _____

Period from: _____ to: _____

Telephone number: _____

Fax number: _____

Postcode/town: _____

Number of participants: _____

Room booking:

Arrival date: _____

Departure date: _____

_____ Single room

Non-smoker Smoker

_____ Double room

Non-smoker Smoker

Arriving here:

- By own means
- By public transport
- By transfer/shuttle service

Technical equipment

- ___ Overhead projector
- ___ Slide projector
- ___ TV/video
- ___ Video camera
- ___ Monitor
- ___ Data projector
- ___ Video projector
- ___ Pin boards
- ___ Facilitator's kit
- ___ Flip chart
- ___ Screen
- ___ Microphone system
- ___ Lectern
- ___ Podium
- ___ Telephone/fax

Conference/event rooms

- Plenary room with ___ m² ___ people
- ___ Group rooms for ___ m² ___ people
- ___ Exhibition space ___ m²

Furnishings

Seating

- U-shaped outer seating
- U-shaped outer and inner seating
- E-shaped T-shaped
- Rows of seats
- Parliamentary
- Block table for _____ people
- Chairs in a circle Semi-circle
- Banquet (round tables)
- Speakers' table for _____ people
- Tables with drawers/storage compartments

Procedure

- Supporting programme
- Information on how to get to the hotel
- Welcome letters
- Reception table

Food and drink

- Seminar package
 - BASIC CITY BUSINESS
 - Half board Full board
- Menu
- Buffet
- Drinks at meals
 - Self-payer All-in-one invoice
- Conference drinks
 - Self-payer All-in-one invoice

Other

- Invoicing
 - Self-payer All-in-one invoice
- Underground parking spaces
 - Self-payer All-in-one invoice

3. Provision costs

3.1 Conference rooms

3.2 Conference technology

3.3 Food and drink (Extract from our drinks and food menu)

3.1 Conference rooms

Room	Surface area	Room rental Euro	For food and drink consumed at a cost of	⇒we add the following amounts to
K1 Tübingen	26m ²	€80.00		
K2 Alb	26m ²	€80.00		
K3 Hohenzollern	29m ²	€80.00	€90.00	€30.00
K4 Blaubeuren	44m ²	€140.00	€210.00	€70.00
K 3+4 combined	73m ²	€200.00	€300.00	€100.00
K5 Lichtenstein	65m ²	€175.00	€240.00	€80.00
K6 Bad Urach	80m ²	€250.00	€330.00	€110.00
K7 Hohenstein	65m ²	€175.00	€240.00	€80.00
K 5+6+7 combined	210m ²	€600.00	€900.00	€300.00
K8 Filderstadt	60m ²	€160.00	€240.00	€80.00
K9 Rottweil	48m ²	€140.00	€210.00	€70.00
K 8+9 combined	108m ²	€300.00	€450.00	€150.00
K10 Achalm	50m ²	€110.00		
K11 Honau	60m ²	€110.00		

Agreed provision costs apply only to the rooms as well as to the furniture required by you, insofar as is this available in the hotel. Technical devices are not included in the provision costs.

3.2 Conference technology

Flip chart (including paper and pens)	€ 5.00
Overhead projector (including screen and pens)	€ 16.00
Slide projector (including screen and pens)	€ 16.00
Pin board	€ 5.00
Facilitator's kit	€ 18.00
Video camera	€ 45.00
Video & monitor (70cm)	€ 40.00
Projection screen (2.80 x 2.80m)	€ 55.00
Microphone system (amplifier, 2 wireless microphones, 1 stand microphone)	€ 85.00
Podium (per part, 1 x 2 metres)	€ 13.00
Dance floor (20m ²)	€ 55.00
Fax machine	€ 20.00
Projector <i>(for seminar packages for 70 or more participants)</i>	€ 50.00 Free
Photocopier	On request
Video projector	On request
Simultaneous interpreting system	On request
Interpreter	On request
Telephone/fax machine (per unit)	€ 0.20
Photocopy (per sheet)	€ 0.25
Slide copy (per sheet)	€ 1.00
Secretariat service (per hour)	€ 26.00

Obviously we would be pleased to organise additional technical equipment for you.

The prices shown are per day and according to availability.

3.3 Offers

Food and drink

Conference drinks

Hot drinks:

Coffee/Kaffee Haag	Pot of 8 cups	€ 17,20
--------------------	---------------	---------

Tea (samovar)

Selection of different black teas, green tea
and different herbal teas

Pot of 8 cups	€ 16.50
---------------	---------

A glass of tea	€ 3,20
----------------	--------

Refreshments (drinks):

Juices	0.20 litres	from € 3,50
		to € 3.90

(apple, orange, red currant nectar, grapefruit, peach, multi-vitamin)

Teinacher mineral water	0.25l	€ 3,50
-------------------------	-------	--------

Teinacher mineral water	0.50 litres	€ 4.10
-------------------------	-------------	--------

Teinacher mineral water	0.7 litres	€ 5.10
-------------------------	------------	--------

Teinacher mineral water gourmet	0.75 litres	€ 5,50
---------------------------------	-------------	--------

Fanta/Cola	0.20 litres	€ 3,50
------------	-------------	--------

Schweppes Lemon and Tonic	0.20 litres	€ 3,70
---------------------------	-------------	--------

3.3 Finger food

Minimum order of 10 pieces/depending on selection

Cold:

Buttered pretzels	Piece	€ 3,20
Bread rolls with a savoury spread (Sausage, cheese or fish salad)	Piece	€ 4,50

Pumpernickel with:

Egg cream filling	Piece	€ 3,00
Fresh herbed cream cheese	Piece	€ 3,00
Herring cutlets	Piece	€ 3,80
Salmon mousse	Piece	€ 3,90

Baguette canapes with toppings:

Choice of French bread or wholemeal bread

French brie cheese and grapes	Piece	€ 3.90
Milanese salami with pickled vegetables	Piece	€ 3.90
Cooked ham, mandarin oranges	Piece	€ 3.90
Parma ham, grated parmesan	Piece	€ 4,30
Roast beef on Waldorf salad	Piece	€ 5,10
Soft cheese with pepper	Piece	€ 4,30
Trout mousse with apples and walnuts	Piece	€ 5,00
Marinated salmon with graved salmon sauce	Piece	€ 5,00
Duck liver terrine with orange	Piece	€ 6,10
Pork medallions with cheese mousse	Piece	€ 6,20

Finger food (continued)

Minimum order of 10 pieces/depending on selection

Hot

Chicken wings	3 pieces	Portion	€ 4,90
Puff pastry filled with salmon and dill		Piece	€ 3,50
Alsatian tarte flambee			
Bacon and sour cream		Piece	€ 3,20
Meatballs with hot chilli sauce		2 pieces	€ 3,50
Mini spring rolls	3 pieces	Portion	€ 3.80
Croissants filled with ham and cheese		Piece	€ 3,90
Quiche Lorraine		Piece	€ 3.60
Baked shrimps in panada		Piece	€ 4,20
Savoury pastries, one portion consisting of four different varieties		Portion	€ 5,50

Vegetarian break-time snacks

Vegetarian puff pastry parcels filled with spinach, leeks or tomatoes		Piece	€ 3,50
Cream cheese jalapenos		Piece	€ 3.80
Fresh cheese in a chilli pepper with a crispy crust			
Spicy onion rings	3 pieces	Portion	€ 4,20
Onion rings in batter			
Broccoli and cheese nuggets in batter		Piece	€ 3.80
Mozzarella sticks in spicy batter		Piece	€ 3.80

We also serve tasty dips/sauces for you:

sweet, spicy, curry or barbecue

Finger food (continued)

Minimum order of 10 pieces/depending on selection

Sweets

Braided yeast bun	Piece	€ 3,60
Madeira cake	Piece	€ 3,60
Small Danish pastries	Piece	€ 3,00
Tea cakes	Portion	€ 3,50
Croissants	Piece	€ 3,00
Raspberry cream tarts	Piece	€ 4,10
Black Forest cherry roll	Piece	€ 4,10
Mini cream puffs with vanilla cream	3 pieces	€ 3,50
Apple tart with cinnamon sugar		
Vanilla sauce	Piece	€ 4,10
Cheese cake	Piece	€ 4,50
Fruit cake	Piece	€ 4,50
Tarts	Piece	€ 5,40

4. A description of the hotel

4.1 Furnishings

4.2 Map with directions to the hotel



4.1 Facilities

Service

- 24-hour **reception**
- **Washing service** within one day
- **Wi-fi**
- **Rental car** booking
- **Sauna** and fitness
- **City bikes**
- **Underground car park** with 80 parking spaces

Rooms

- **74 standard rooms** with bath/shower/WC on 4 floors
- **81 comfort rooms** and **apartments**,
- **4 studios (2- and 3-rooms apartments)**
- Hair dryer and cosmetic mirror
- Satellite TV, radio and pay TV
- Mini-bar
- **Wi-fi**
- **Private fax machine** on request (analog)
- Large **work and storage spaces**
- Non-smoking rooms (3 floors)

Food

- Varied and large **breakfast buffet**
- **Business lunch and dinner** with international, regional and vegetarian specialities
- **Garden terrace**, restaurant and bar
- **Event rooms** for companies and family celebrations

CITY HOTEL Reutlingen

Am Echazufer 22
D-72764 Reutlingen, Germany

Tel.: 07121-924 0
Fax: 07121-924 444

E-mail address: bankett@city-hotel-reutlingen.de

4.2 Map with directions to the hotel

CITY HOTEL Reutlingen

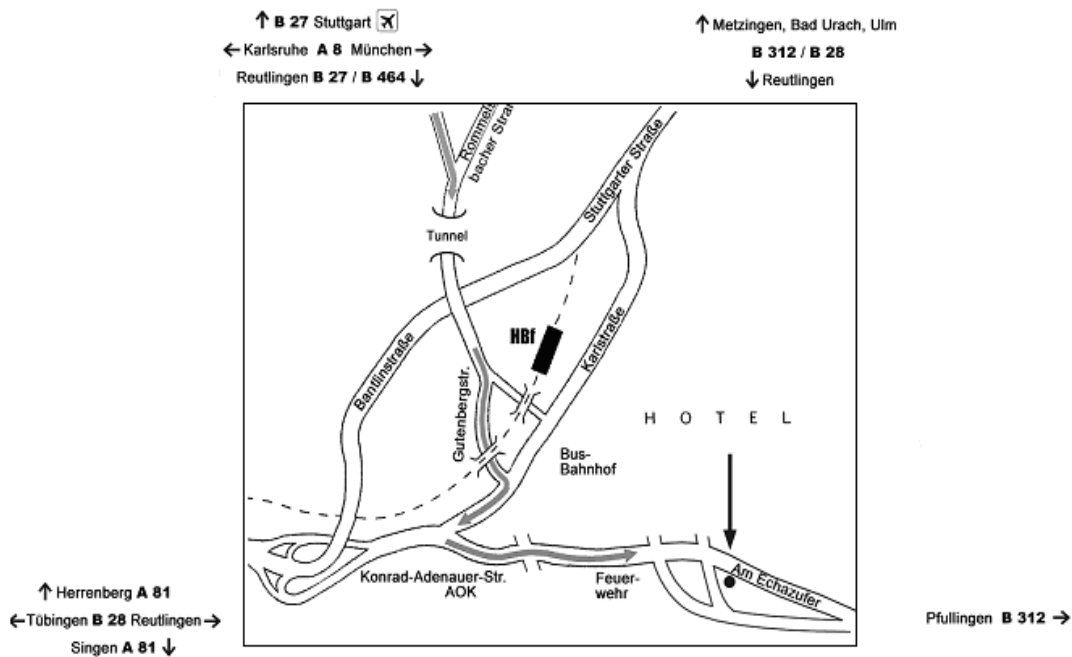

By car:

When coming from Stuttgart via the A8 motorway, take exit No. 52, "Stuttgart Degerloch", onto the B 27 in the direction of Reutlingen/Tübingen, then onto the B 464 in the direction of Reutlingen.

From the entrance to the town, travel in the direction of the centre onto the B 312 in the direction of Pfullingen.

The CITY Hotel Reutlingen is located on the right by the town exit.

When coming via the A 81 motorway, take exit No. 28, "Herrenberg", onto the B28 as far as Tübingen.

Follow the "Reutlingen" road signs there. The city centre exit will take you automatically

onto the B132. The CITY Hotel Reutlingen is located on the right by the town exit.

Centre: 3 minutes. Train station: 5 minutes. Stuttgart Airport: 30 minutes.

Public transport:

From the main train station in Stuttgart (hourly from 7am to 11pm) DB regional express in the direction of Tübingen,

from the main train station in Reutlingen take the number 8 to the bus stop in Georgenstrasse (every half hour from 5am to 11pm)

Centre: 10 minutes. Train station: 10 minutes. Stuttgart Airport: 90 minutes.

5. Supporting programmes and leisure time offers

Would you like your guests to remember their stay in Reutlingen for as long as possible?

And for your event to be an unforgettable experience..? Then we have just the right thing for you.

Follow in **Michael Schumacher's footsteps** and race around the track in the **Go-Kart Motodrome**. Take part in neck-and-neck races, with everyone against each other. Who will be the winner? (Also possible for groups, with an awards ceremony and prizes).

Nine-pin bowling. **Bowl** like the world champions!

Become a **punting professional** and create your own "**punting diploma**". To increase your strength there's a hearty snack in the punt. (Only from May to October.)

Visit the **SI-Centrum in Stuttgart** - there's a lot to see there

The **hugely successful musicals "Dance of the Vampires"** and

- **"We Will Rock You"** await you
- Let yourself really be spoiled in the **Schwabenquellen** spa/waterpark complex
- Play a round of black jack in the **casino**
- Visit the numerous **restaurants** and **pubs**

Would you like to play golf like the professionals? No problem! On the nearby golf course you will be initiated into the high art of holing balls.

Would you like to learn about the **beautiful cultural sights in the region**? Then don't waste any time - numerous caves, castles and towns are waiting to be explored by you. For example:

- **Wimsen Cave** - The only cave it is possible to navigate by punt in Germany
- **"Bear and Mist Cave"** - Unique stalactite and stalagmite caves and wonderful natural monuments in the Swabian Alps
- **Hohenzollern Castle**, where Emperor Wilhelm II once bestrode the parquet floor
- **Lichtenstein Castle**, Wilhelm Hauff's fairy tale castle
- **Bebenhausen Monastery**, a cistercian monastery, one of the most important and most impressive monastery complexes in south-west Germany
- During an interesting guided **sightseeing walk around the town**, discover **Reutlingen's** somewhat different side or the **University Town of Tübingen** (multilingual tours are also possible).

or, or, or...

Talk to us. Together we'll find whatever is right for your event.

General terms and conditions for events

I. Scope of application

The General Terms and Conditions apply to contracts and the provision on a rental basis of conference, banqueting and event rooms in the hotel for the running of events such as banquets, seminars, conferences, etc. as well as for all other associated services and supplies provided by the hotel. The subletting or leasing of the rooms, surface areas or showcases and invitations to interviews, sales events or other types of events require the prior written permission of the hotel.

Business conditions of the event organiser only apply if they were expressly agreed beforehand in writing.

II. Conclusion of contract, contractual partners, contractual liability

The contract is concluded when the hotel accepts the event organiser's order (confirmation); these are contractual parties.

2. If the customer is not the event organiser *itself* or if a commercial mediator or organiser is engaged by the event organiser, then these together are joint and severally liable with the event organiser for all obligations arising from the contract.

3. The hotel is liable for its obligations arising from the contract. This liability is limited to deficiency in performance which, except in the area typical of its performance, is put down to intent or gross negligence on the part of the hotel. Furthermore, the event organiser is obliged to inform the hotel in good time of the possibility of exceptionally significant damage occurring.

III. Services, prices, payment

1. The hotel is obliged to provide the services requested by the event organiser and promised by the hotel.

2. The event organiser is obliged to pay the prices agreed with the hotel for these services. This also applies to services provided and expenses incurred by the hotel for third parties in connection with the event.

3. The agreed prices include all applicable VAT. If the time between conclusion of the contract and the event exceeds 4 months, and if there is an increase in the prices generally calculated by the hotel for services of this kind, then the contractually agreed price can be increased appropriately, though by 10% at most.

4. Hotel bills without a due date are payable without deduction within 10 days of receipt. In the case of arrears, the hotel is entitled to charge interest 4% higher than the respective bank rate of the German Bundesbank. The event organiser reserves the right to assert lower damages, while the hotel reserves the right to assert higher damages.

5. The hotel is entitled to request an appropriate advance payment at any time. The amount of the advance payment and the payment deadlines can be agreed in writing in the contract.

IV. V. Withdrawal by the hotel

1. If the advance payment is not made, including after a suitable grace period set by the hotel with threats of withdrawal, the hotel is entitled to withdraw from the contract.

2. Furthermore, the hotel is entitled to withdraw extraordinarily from the contract for objectively justifiable reasons, for example if

* Events are booked while providing misleading or false details of important facts

e.g. by the event organiser or related to the purpose of the event;

the hotel is justified in assuming that the event can endanger the smooth running of the hotel, its security or its reputation with the public

without the hotel's managerial or organisational staff being to blame for this.

* A violation of 1.2 above exists

3. The hotel must inform the event organiser without delay that it is exercising the right of withdrawal.

4. The event organiser will have no claim to compensation against the hotel except in cases of intentional or gross negligent behaviour by the hotel.

V. Withdrawal by the event organiser (cancellation)

1. If the event organiser withdraws, the hotel is entitled to bill for the agreed rent if subletting is not possible.

2. If the event organiser withdraws between the eighth and the fourth week before the date of the event the hotel is entitled, in addition to the rental price, to bill for 35% of the turnover lost on the food, and to bill for 70% of the turnover lost on the food if withdrawal occurs at a later time.

3. The turnover on the food is calculated according to the following formula: $\text{Menu price for a banquet} \times \text{the number of people}$

If no price was agreed for the menu, the most inexpensive 3-course menu for the respective valid event offer is used as a basis.

4. Expenses saved in accordance with Nos. 2 and 3 are thus satisfied. The event organiser reserves the right to request proof of lower damages, while the hotel reserves the right to provide proof of higher damages.

VI. Changes to the number of participants and the date of the event

1. The banqueting department must be informed of a change to the number of participants of more than 5% at the latest 5 working days before the event begins; the hotel's permission is required for this.

2. A reduction in the number of participants by a maximum of around 5% is recognised by the hotel when billing takes place. For deviations above and beyond this, the originally registered number of participants less 5% is used as a basis.

3. If a deviation upwards occurs, the actual number of participants is charged for.

4. Where deviations of more than 10% are concerned, the hotel is entitled to reset the agreed prices as well as to switch the confirmed rooms, unless this is unreasonable for the event organiser.

5. If the times when the event begins or ends are postponed without the prior written permission of the hotel, the hotel can bill for the additional costs of the related work, unless the hotel is at fault.

VII. Food and drink brought by the event organiser

As a rule, the event organiser may not bring food and drink to events. Exceptions to this rule require a written agreement with the banqueting department. In such cases a contribution to cover the overheads will be billed for.

VIII. Technical equipment and connections

1. If the hotel obtains technical and other types of equipment from third parties for the event organiser at its instigation, it acts on behalf of, on the authority of and for the account of the event organiser. The event organiser is liable for the careful handling and the proper return of same. It releases the hotel from all third-party claims arising from the provision of this equipment.

2. The use by the event organiser of its own electrical systems while also using the hotel's electricity supply mains requires the hotel's written permission. To the extent that the hotel is not responsible for them, faults or damage to the system's technical systems caused by use of these devices occur at the event organiser's expense. The electricity costs arising from this use may be calculated and charged by the hotel in the form of a flat-rate sum.

3. With the hotel's agreement, the event organiser is entitled to use its own telephone, fax and data transferral equipment. The hotel can request a connection charge for this.

4. If suitable systems in the hotel are not used because the event organiser is connecting its own systems, the hotel can charge a fee for non-use.

5. Whenever possible, faults in the technical equipment or other equipment provided by the hotel are remedied immediately. Payments cannot be withheld or reduced if the hotel is not responsible for these faults.

IX. Loss of or damage to objects brought by the event organiser

1. Exhibition-related objects or other types of objects, including personal objects, brought along by the event organiser are used in the event rooms in the hotel at the event organiser's risk. Except in cases of gross negligence or intent on its part, the hotel assumes no liability for their loss, destruction or damage.

2. Decorative materials brought by the event organiser must be in accordance with the fire safety regulations. The hotel is entitled to request official proof of this. Due to possible damage, the installation and affixing of objects must be agreed in advance with the hotel.

3. The exhibition-related objects or other types of objects must be removed without delay after the end of the event. If the event organiser fails to do so, the hotel may remove and store the objects at the event organiser's expense. If the objects remain in the event room, the hotel can charge for room rental for the duration. The event organiser reserves the right to request proof of lower damages, while the hotel reserves the right to provide proof of higher damages.

X. Event organiser's liability for damages

1. The event organiser is liable for all damage to buildings or stock caused by participants in or visitors to the event, employees, other third parties belonging to it or itself.

2. The hotel can request that the event organiser provide appropriate securities (insurance, deposits, guarantees).

XI. Final provisions

1. Changes or amendments to the contract, order acceptance or these Terms and Conditions for Events must be made in writing. Unilateral changes or amendments by the event organiser are ineffective.

2. The place of performance and payment is the location of the hotel.

3. The exclusive place of jurisdiction for commercial transactions - also for cheque and exchange disputes - is the location of the hotel. If a contractual partner fulfils the requirements of § 38, Paragraph 1 of the ZPO (Swiss Civil Code) and has no general place of jurisdiction in Germany, the place of jurisdiction is the location of the hotel.

4. German law applies.

If individual provisions of these General Terms and Conditions for Events become ineffective or void for, the effectiveness of the remaining provisions is unaffected thereby. The statutory provisions apply.

Addendum for the CITY Hotel for events continuing after midnight

Events that continue beyond midnight on the day of the event are charged for at a rate of €26.00 per hour and service person present.

Valid from January 1, 2023